

Technical Specifications:

Pole Pitch	1mm/2mm/5mm
Resolutions (X4 edge)	1µm, 5µm, 10µm, 20µm
Accuracy (µm)	±10µ, ±20µ, ±50µ
Repeat accuracy	± 1 count
Measuring Lengths	1000, 1100, 1200, 1300, 1400, 1500, 1600, 1700, 1800, 1900, 2000, 2100, 2200, 2300, 2400, 2500, 2600, 2700, 2800, 2900 mm
Current consumption	Typ. 150mA (250mA max)
Power supply	+ 5 VDC (± 5%)
Output signal	Differential Line driver as per EIA RS422 standards. 1Vp-p Sine wave output. (0.6Vp-p – 1.2Vp-p)
Reference mark	Every 50mm
Operating Temperature	0° C to 50° C
Storage Temperature	-20° C to 70° C
Relative Humidity	20% to 80% Non-condensing
Standard Cable length	5 meters armoured cable
Max. cable length	20 meters
Measurement Speed	2MHz (10m/s @ 5µm) 1Vp-p – 10KHz
Protection class	IP-67

Definitions:

Resolution: Resolution of a linear encoder is defined as the smallest measurable positional step. The resolution depends on the grating pitch of the scale and the interpolation factor set in the reader head. The quoted resolution (See table) is after x4 edge multiplication. For 1Vp-p resolution is determined by the interpolation of the user processing system.

Accuracy: The accuracy of the system is such that all positional data-points about the mean error fall within the specified limits for any 1m travel. The reference temperature for the accuracy class is considered as 20° C.

Dimensions:

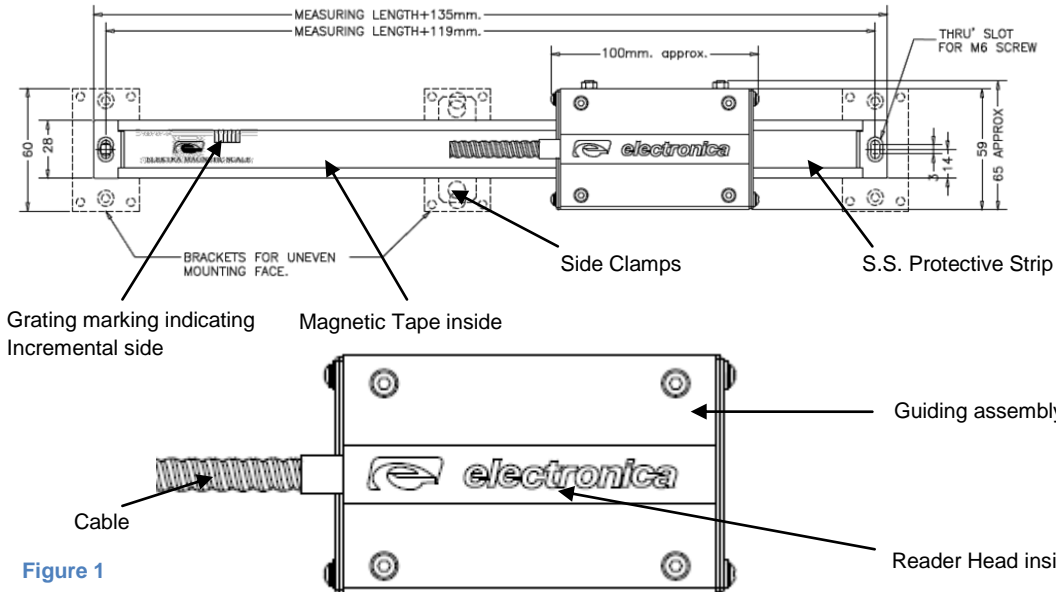
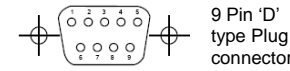

Figure 1

Pin Connection Details:



9 Pin 'D' type Plug connector



STATIC SENSITIVE DEVICE
OBSERVE HANDLING PRECAUTIONS

RS422

Pin	1	2	3	4	5	6	7	8	9
Signal	+ Z	- Z	VCC	Shield	GND	+ A	- A	- B	+ B
Colour	Grey	Brown	Black	Violet	White	Pink	Red	Green	Yellow

1Vpp

Pin	1	2	3	4	5	6	7	8	9
Signal	V0+	V0-	VCC	Shield	GND	V1+	V1-	V2-	V2+
Colour	Grey	Brown	Black	Violet	White	Pink	Red	Green	Yellow

EMRA – for 1mm Pole Pitch
EMRB – for 2mm Pole Pitch
EMRD – for 5mm Pole Pitch

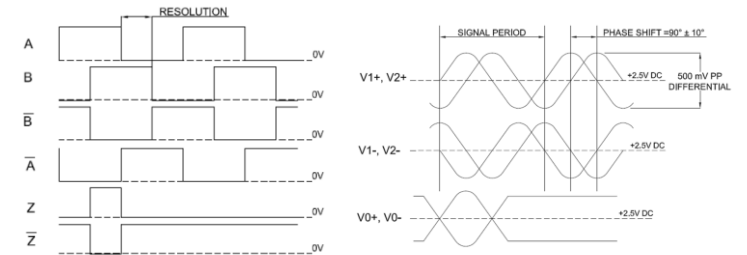

Mounting Tolerances:

Scale: Scale should be aligned with in 0.1mm/m from front side and top side. This alignment should be closer to zero for better results.

If the mounting surface of the machine is even (within 0.1mm/m), then the scale can be directly mounted to the machine.

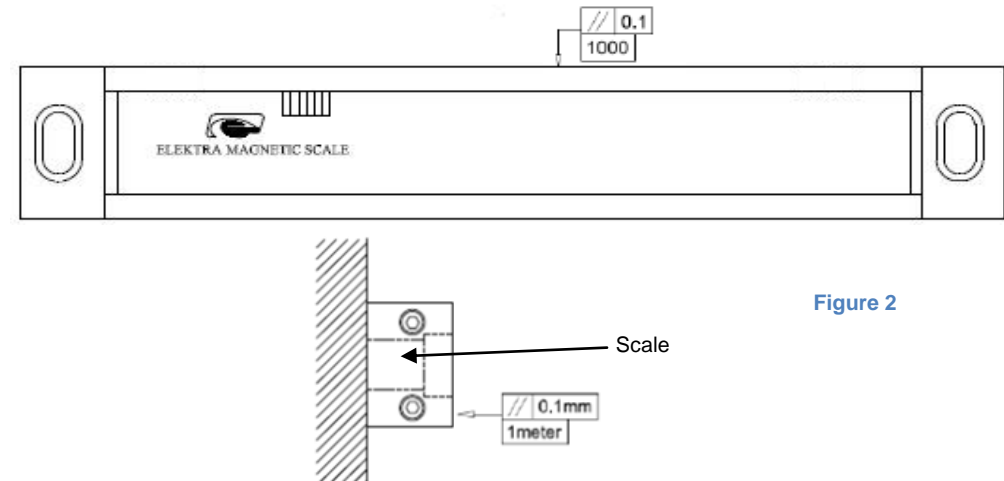

Figure 2

Mounting Instructions:

Attention:

- Prior to mounting clean the mounting area thoroughly of oil, dust, coolant, and burr.
- Ensure the reader head mounting allows the reader head to move freely over the length of the scale.

Mounting the Scale:

- The best location for mounting the scale is as near to the centerline of the slide, or as close to the guide-ways of the machine as possible.
- If the mounting surface of the machine is even (within 0.1mm/m), then the scale can be directly mounted to the machine. Ensure the parallelism to full length of the scale as instructed in the mounting tolerances using a dial indicator.
- If the mounting surface is not even (more than 0.1mm/m) then it is recommended to use the optional scale mounting brackets.
- Mounting brackets should be positioned at the two ends of the scale as shown in the Figure 5. The alignment of the blocks should be checked using dial indicator before mounting the scale. Use side clamps as indicated in Figure 5 at every 500mm.
- Ensure the supplied cover is properly mounted to protect the scale and reader head for the entire length to ensure the reliability and performance of the system. Refer Figure 5.

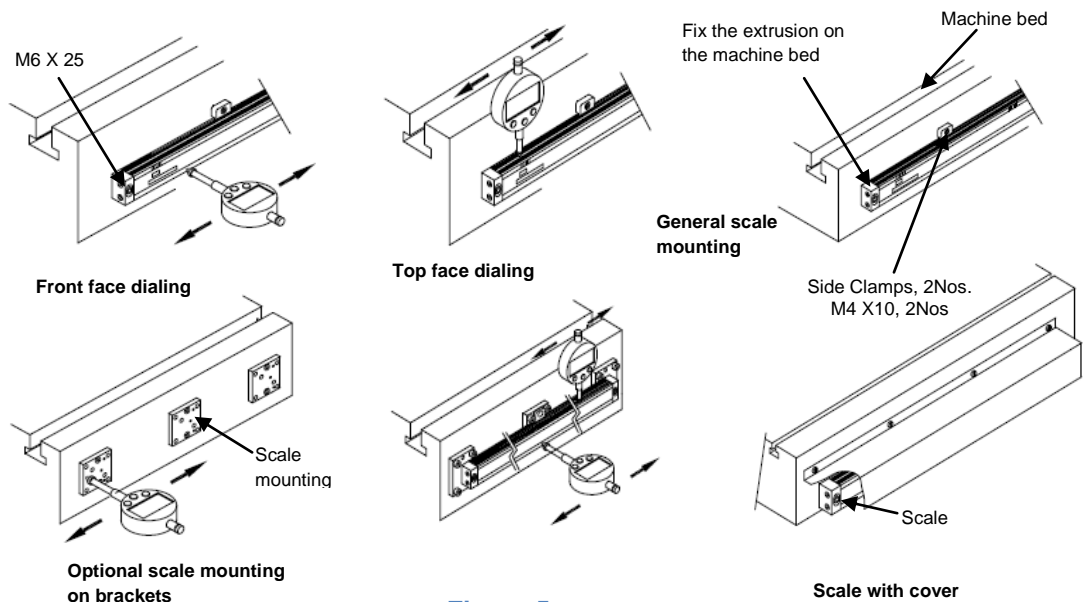

Figure 5

Inspection of Mounting:

Move the slide over the full range of motion to make sure that full machine travel can be obtained without the reader head contacting the scale end brackets. Otherwise the reader will be damaged. Make sure that the plastic shim is removed after installation.

Cable Routing:

- Cable should be routed such that it does not come in between the machine moving parts.
- The bending radius should not be less than 60mm as shown in the figures.
- The encoder cables should not be routed close to high power or high voltage switching sources.
- Where extension leads are used the connectors should be mounted clear of any source of liquid contamination.

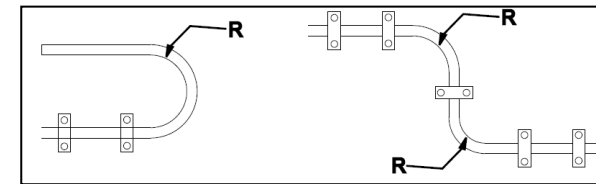

Figure 3

Safety:

- Avoid using the magnetic stand or any permanent magnet close to the magnetic scale any time during its use or during maintenance. This may damage the magnetic scale permanently.

Carriage Mounting:

- Carriage assembly contains M4X6 mounting holes on either side. Machine slides can be directly mounted on carriage assembly.
- Alternately carriage assembly can be mounted using "flexible bracket" (Part No: 162-01-0730) as shown in figure below.

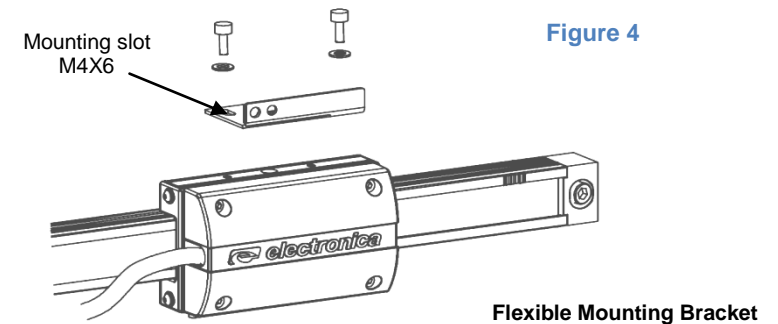

Figure 4

Electronica Mechatronic Systems (India) Pvt. Ltd.

Web: www.electronicaems.com; email: info@electronicaems.com

Code: 0073-14-0980
Update Date: 13th June, 2009